

MHT LIGHTING

PoE FIXTURE

Tape Series

LED BULB Series

FEATURES

- Versatile PoE bulb for existing fixtures
- Controlled with Inspextor

GENERAL INFORMATION

Applications	Interior/Hospitality
Warranty	3-Year Warranty
Construction	Durable White Polycarbonate Housing and Lens or Filament LED and Clear Glass Construction
Certifications	  

PRODUCT DATA

Electrical	Non-Integrated PoE Low Voltage Driver Node, Sensor, Emergency Battery Backup.
Mounting	E26 Base
Lumens	700 - 1,400 Lumens
Max Input Power	7W/12W
CRI	> 80
CCT	2700K/3000K/3500K/4000K/5000K
L70 Lifetime	> 50,000 Hours
Rated Lifespan	> 50,000 Hours
Dimensions	7W Frosted - 2.36" x 4.2" 7W Clear - 2.54" x 5.41" 12W Frosted - 2.75" x 5.1"

ORDERING INFO: Sample Code - MHTI-BULB-SC-7E-27K-CL

Series	Wattage	Color Temperatures	Options
MHTI-BULB-SC			
MHTI-BULB-SC	7E - 7W (Up to 6 Bulbs per Port) 12E - 12W (Up to 4 Bulbs Per Port)	27K - 2700K 3K - 3000K 35K - 3500K 4K - 4000K 5K - 5000K	CL - Clear Glass FL - Frosted PC



DIMENSIONS

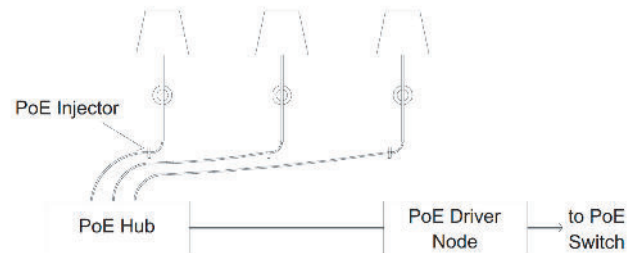
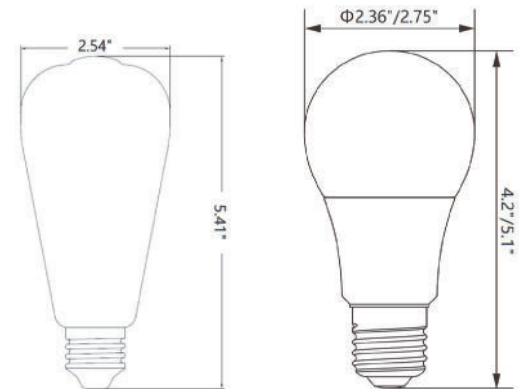

FIXTURE PERFORMANCE

Model	Max Wattage	Lumens/Watt
MHTI-BULB-SC-7E-3K-FL	7W	115 lm/W
MHTI-BULB-SC-7E-3K-CL	7W	115 lm/W
MHTI-BULB-SC-12E-3K-FL	12W	115 lm/W

 MHT Technologies