

MHT LIGHTING

PoE FIXTURE

Line Voltage Fixture



MHT DL-4-S Series

FEATURES

- PoE Enabled that works with Inspextor
- 0-10V Line Voltage Available

GENERAL INFORMATION

Applications Airports, Corporate Campuses, Data Centers, Retail, and Health-care Facilities

Warranty 5-year Limited Warranty

Construction Lightweight Die-cast Aluminum Housing with Stainless Steel Spring Clips
Lens: White Polycarbonate Beam Angle: 70°

Certifications



PRODUCT DATA

Electrical Non-Integrated PoE Low Voltage Driver Node or 0-10V LED Driver

Mounting Recessed ceiling mount

Lumens 1,000 - 2,000 Lumens

Max Input Power 10/15/20W

CRI > 80

CCT 3000K/3500K/4000K/5000K

L70 Lifetime > 50,000 Hours

Rated Lifespan > 60,000 Hours

Dimensions 4.75" x 4.75" x 5.76"

DIMENSIONS

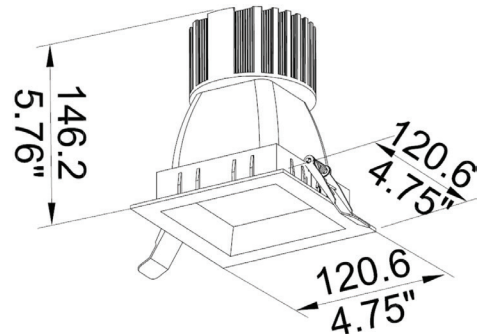

PHOTOMETRICS

MHTi-DL-SC-4-S-15E
Luminaire Output: 1,543 lumens, 15 Watts

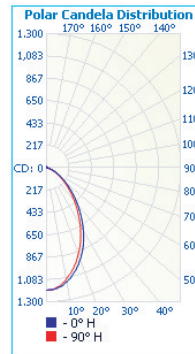

	Illuminance at a Distance	
	Center Beam fc	Beam Width
1.5ft	529 fc	2.0 ft 2.0 ft
3.0ft	132 fc	4.0 ft 4.0 ft
4.5ft	58.8 fc	6.0 ft 6.1 ft
6.0ft	33.1 fc	8.0 ft 8.1 ft
7.5ft	21.2 fc	10.0 ft 10.1 ft
9.0ft	14.7 fc	12.1 ft 12.1 ft

■ Vert. Spread: 67.6°
■ Horiz. Spread: 67.9°

FIXTURE PERFORMANCE

Model	Max Wattage	Lumens/Watt
MHT-DL-4-S-10W	10W	100 lm/W
MHT-DL-4-S-15W	15W	100 lm/W
MHT-DL-4-S-20W	20W	100 lm/W

ORDERING INFO: Sample Code - MHTi-DL-SC-4-9E-3K

Series	Size & Wattage	Color Temperatures	Options
MHT-DL-4-S			
PoE: MHTi-DL-4-S-SC LV: MHTL-DL-4-S	10W - 4" - Square 10W (PoE/LV) 15W - 4" - Square 15W (PoE/LV) 20W - 4" - Square 20W (PoE/LV)	3K - 3000K 35K - 3500K 4K - 4000K 5K - 5000K	(Blank) - Standard in White Trim

MHT Technologies