

mhtlighting

illuminating PoE technology



MHTL-BL

LED BARN LIGHT SERIES

(40W / 55W / 70W)

FEATURES

- ADC12 Cast Aluminum Body
- Prismatic Polycarbonate Diffuser
- Selectable Power 40W / 55W / 70W
- Comes with Built-in Photozell Control
- Standard Pole Mount or Wall Mount
- IP 65 Wet Location Rated

GENERAL INFORMATION

Applications Building Exterior, Local Streets, Security Lighting

Warranty Limited 10-year Warranty

Construction Cast Aluminum Body Construction - Black
Prismatic Polycarbonate Diffuser

Certifications



PRODUCT DATA

Universal Input Voltage 120 - 277V 50Hz/60Hz

Power Factor > 0.90 @ 277V

THD < 10% @ 277V

Mounting Standard Pole Mount

Lumens 4,800 lm / 6,600 lm / 8,400 lm

Max Input Power 40W / 55W / 70W

CRI > 80

Color Temperature (CCT) 3000K / 4000K / 5000K

L70 > 60,000 Hours

Rated Lifespan > 100,000 Hours

DIMENSIONS

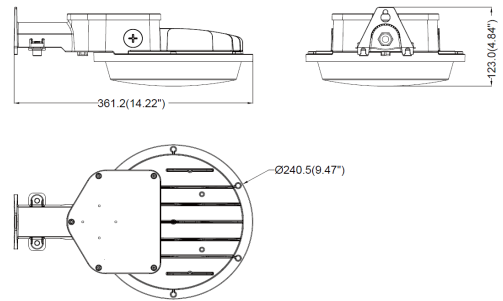

PHOTOMETRICS

MHTL-BL-55E-5K-U
Luminaire Output: 6,600 lumens, 55.6 Watts

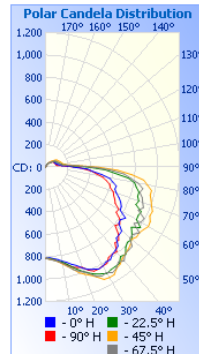

Center Beam fc	Beam Width	
	Beam Width	Beam Width
3.3ft	75.1 ft	99.4 ft 35.5 ft
6.7ft	18.2 ft	201.9 ft 72.1 ft
10.0ft	8.17 ft	301.3 ft 107.7 ft
13.3ft	4.62 ft	400.8 ft 143.2 ft
16.7ft	2.93 ft	503.2 ft 179.8 ft
20.0ft	2.04 ft	602.6 ft 215.3 ft

■ Vert. Spread: 172.4°
■ Horiz. Spread: 159.0°

FIXTURE PERFORMANCE

Model	Input Power	CCT	Lumen (lm)	Dimensions (inch)
MHTL-BL-40E-5K-U	40W	5000K	4,800	14.22" x 9.47" x 4.84"
MHTL-BL-55E-5K-U	55W	5000K	6,600	14.22" x 9.47" x 4.84"
MHTL-BL-70E-5K-U	70W	5000K	8,400	14.22" x 9.47" x 4.84"

ORDERING INFO: Sample Code - MHTL-BL-70E-5K-U-PC

Series	Wattage	Color Temperature	Input Voltage	Mounting	Options
MHTL-BL					
MHTL-BL	40 55 70	3K=3000K 4K=4000K 5K=5000K	U=120-277V	(Blank) - Standard Pole Mount or Wall Mount	(Blank) - Standard in Black (Blank) - Built-in Photozell Control