

# INSPEXTOR

## PRODUCT SERIES SPEC SHEET

### MHTi-NODE-CORE

The Inspextor platform is a **PoE Lighting Management System** that enables building automation and data collection. It utilizes Power over Ethernet (PoE) technology for safe and efficient low voltage operation. The MHTi-NODE-CORE supports a variety of applications, offering options for Constant Current (CC), Constant Voltage (CV) and Constant Power (CP) lighting and other DC power needs from 12V to 48VDC. These network nodes receive power and data from the PoE switch and seamlessly integrate with other devices in the network, such as sensors, shades, and wall switches, all controlled by the Inspextor system. They support advanced lighting controls features such as dimming, tunable white, and RGBW color-controlled lights. They are designed for easy installation and setup, automatically obtaining an IP address from the local network.

### ELECTRICAL SPECIFICATIONS

MHT PD Interface	IEEE 802.3bt PD Type 4, Class 8 compliant input with LLDP extensions for negotiating power above 30W using all four pairs. Supports IEEE 802.1X authentication.
Input	50-60VDC / 1.8A / 90W maximum
Output	12-48VDC / 3.0A / 80W maximum - 1 Channel Linear CC/CV/CP - 4 Channel PWM common anode
Sensors	24VDC / 0.1A - WS: 1 MHTi Wall Switch (~15V) - IN: Analog Input (0-10V or dry contact 10-24V) internal pull-down
Nominal Standby Power	2W
PoE Input Connection	RJ45 jack for CAT5e/6/6A cable to PoE PSE device
Device Type	Class 2 electrical device



### MHT Technologies

**Innovation Lab:**  
241 W. 37th St., Suite 1202, New York City, NY 10018

**HQ & Warehouse:**  
1961 Richmond Ter, Staten Island, NY 10302

Tel: 718 524 4370

[www.mht-technologies.com](http://www.mht-technologies.com)



MHT Technologies, reserves the right to make any design changes for continuous improvement which will not affect the overall appearance or performance.

## PRODUCT FEATURES

- 90W PoE Gateway + 80W RS-485 Driver
- Ethernet Stack – UDP/TCP-IP, TLS, CoAP/MQTT/HTTPS
- USBC Serial Console for Gateway and Driver
- Linear CC/CV/CP Output
- 4 Channel PWM
  - o 1 Channel CV PWM Dimming
  - o 2 Channel Tunable White Light
  - o 4 Channel RGBW Color Control Light
- Sensors
  - o 24VDC / 0.1A output
  - o WS – digital input/output for MHTi 4 and 7 Button Wall Switches
  - o IN – Analog input for 0-10V sensors and 10-24V dry contacts
  - o RS-485 A+/B-

## Applications

- Suitable for LED related fixture or appliances
- Installed remotely or inside luminaire

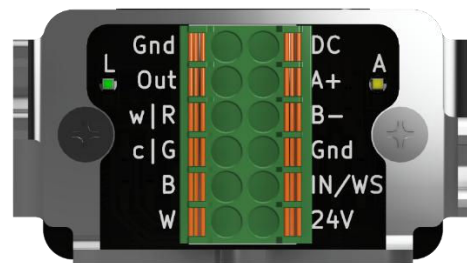

 MHT Technologies

**Innovation Lab:**  
241 W. 37th St., Suite 1202, New York City, NY 10018

**HQ & Warehouse:**  
1961 Richmond Ter, Staten Island, NY 10302

Tel: 718 524 4370

[www.mht-technologies.com](http://www.mht-technologies.com)



MHT Technologies, reserves the right to make any design changes for continuous improvement which will not affect the overall appearance or performance.

## PRODUCT DIMENSIONS

The product has an aluminum enclosure with mounting flanges. Secure with an M4 or #8 screw at least two locations. For proper heat transfer choose a target mounting surface suitable for heat dissipation. Compress the bottom of the enclosure tightly against the mounting surface.

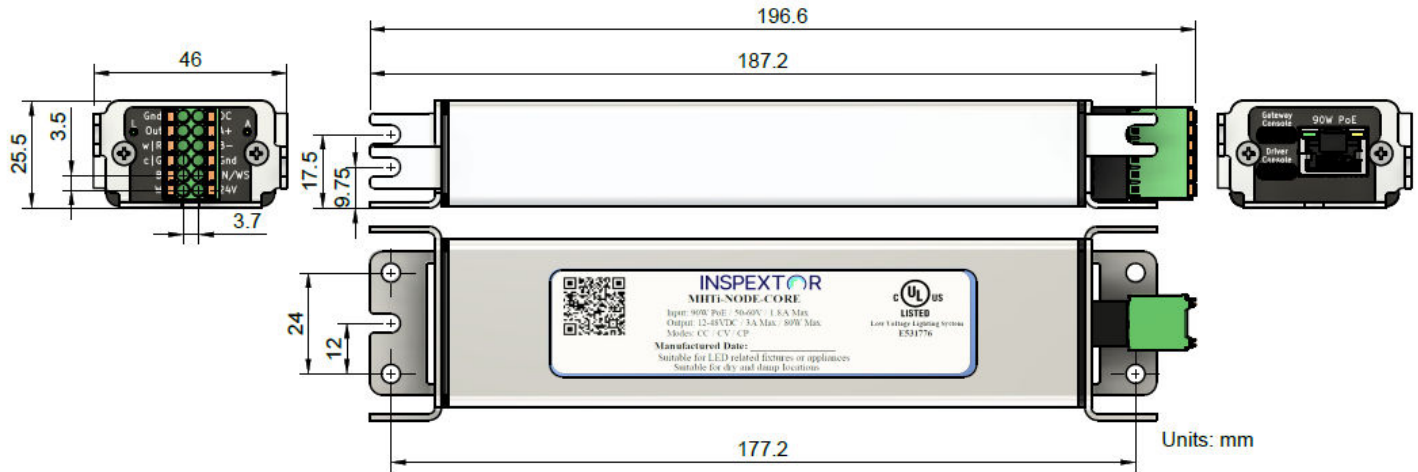

Dimensions Overall	196.6mm (7.74in) L x 46mm (1.81in) W x 25.5mm (1in) H
Mounting Dimensions	4 Holes, 2 Slots: 4.5mm (0.177in) D 177.2mm (6.97in) L x 24mm (0.94in) W

## NODE ENVIRONMENTAL REQUIREMENTS

The product should be used for indoor applications. Liquids and dust can ingress through small gaps around connections. Avoid installation locations that can become wet or are particularly dusty.

Operating Temperature	-20C to 40C
Operating Environment	For dry or damp locations
Operating Humidity	10% to 80% RH non-condensing
Storage Temperature	-20C to 70C
Storage Humidity	5% to 95% RH non-condensing

## WIRING

The output connector provides several features. Connect a CC light or other continuous loads like shades to between the positive Out terminal and the negative Gnd terminals. These provide the primary voltage regulator output. A CC light can be dimmed linearly by adjusting the current or power. For CV lights or other loads that require PWM dimming connect between the positive Out terminal and the first PWM channel “w | R” negative terminal. For tuneable white load Out is common anode and the warm cathode connected to “w | R” and the cool cathode to “c | G”. Multi color RGBW lights can be also connected common anode to Out and cathodes to each of the respective PWM terminals.

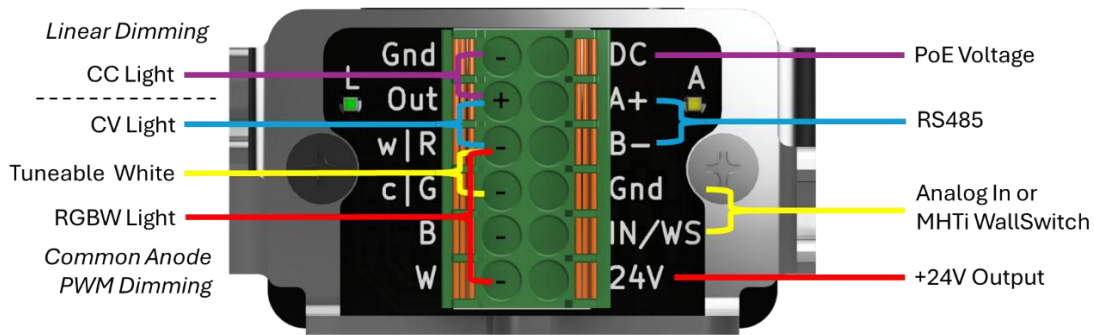

The full PoE Voltage is output at the “DC” terminal. RS485 is available at A+ and B-. An analog sensor or an MHTi WallSwitch can be connected at “IN/WS”. And a +24V output is also available to power external sensors.

The output connector is Amphenol Anytek NL12105200G0G 3.5mm pitch Screwless - Leg Spring, Push-In Spring terminal plug. Recommend solid wire 16-24AWG stripped to 9-10mm length. Otherwise for stranded wire should be terminated with a crimped ferrule 12mm length.



**Innovation Lab:**  
241 W. 37th St., Suite 1202, New York City, NY 10018

**HQ & Warehouse:**  
1961 Richmond Ter, Staten Island, NY 10302

Tel: 718 524 4370

[www.mht-technologies.com](http://www.mht-technologies.com)



MHT Technologies, reserves the right to make any design changes for continuous improvement which will not affect the overall appearance or performance.